



# YK3

## SINGLE POINT LOAD CELL

### *applications*

- Hopper & Netweight Weighing
- Platform and Belt Conveyor Scales
- Checkweighing
- High Moment/Off-Center Loading
- OEM and VAR Solutions

### *features*

- 10 to 200 lbs. Capacities
- Low Profile/Compact Size
- Excellent Overall Performance
- 0.03% Accuracy Class
- Exceeds NIST H-44 Requirement
- Application Versatility
- Stainless Steel Element
- IP67 Environmental Sealing
- Two Year Warranty

SENTRAN, LLC  
California Commerce Center  
4355 Lowell Street  
Ontario, CA 91761-2225

Toll Free: 1(888) 545-8988  
Phone: 1(909) 605-1544  
Fax: 1(909) 605-6305  
Email: [mail@sentranllc.com](mailto:mail@sentranllc.com)  
URL: [www.sentranllc.com](http://www.sentranllc.com)



#### *Application Tip:*

The Model YK3 Series load cells feature Triple Beam Technology, field-proven as the best solution for High Moment Weighing and Overload Protection.

The YK Series is a robust, high performance, bonded foil strain gage load cell constructed of electro-polished stainless steel (YK3). The YK Series is designed to accurately measure compression loads for single cell applications in the capacity range of 10 lbs. to 200 lbs. The field proven *triple-beam* design readily tolerates high moments induced by angular, eccentric and off-center loading, with minimal sensitivity to these anomalies. To achieve a sealing rating of IP67 (thoroughly sealed against airborne particles and the effects of immersion in water up to 1 meter.) proprietary, multi-redundant environmental barriers are integrated to protect the strain gage area and all electronic components. Additional protection is provided by the stainless steel side covers, which also serve to enhance the aesthetics of the YK Series as a component of an assembly or measurement system. The cable is a durable polyurethane-jacketed cable, with a tin-copper braided shield for mechanical protection and to minimize the effects of RFI and EMI. The attributes of the YK3 Series makes it an ideal choice for low range force measurements, small hopper and platform weighing, conveyor scales and O.E.M. weighing situations where an exceptionally rugged moment-compensated, well sealed, and high performance load cell solution is needed. Non-standard or custom configurations can be accommodated consistent with solutions-driven requirements.

*Innovative Measurement Solutions*



**performance**

The Model YK Series load cells feature Triple Beam Technology.

Rated capacities (lbs.):	10, 15, 25, 50, 100, & 200
Rated output (FSO)	2 mV/V + 25%/- 10%
Combined error	≤ 0.03 % FSO
Non-linearity	≤ 0.03 % FSO
Hysteresis	≤ 0.02 % FSO
Non-repeatability	≤ 0.01 % FSO
Moment Sensitivity	See Table Below
Maximum Moment	See Table Below
Creep (30 minutes)	≤ 0.03 % of load
Zero balance	≤ 1 % FSO
Zero return (20 minutes)	Better than 0.03 % FSO

**mechanical**

Material:	17-4ph Stainless steel
Finish:	Electro-polished
Safe overload	Compression/Tension: 150% FSO Side load: 50% FSO
Ultimate overload	Compression/Tension: 300% FSO Side load: 100% FSO
Deflection	See Table Below
Weight	See Table Below

**electrical**

Input impedance	400 ± 50 ohms
Output impedance	352 ± 3 ohms
Insulation resistance	>5000 Megohms @ 50VDC
Excitation Voltage	10 V AC/DC (15 V maximum)
Cable Color code:	+ Excitation (red) - Excitation (black) + Output (green) - Output (white) Shield (bare)
Cable type	4-conductor; 22 AWG; tin-copper braided shield; polyurethane jacket
Cable termination	Finished conductors

**environmental**



Temperature, operating	4 to +140 °F (-20 to +60°C)
Temperature, compensated	14 to +104 °F (-10 to +40°C)
Temperature effects:	Zero < 0.0015% FSO/°F < 0.0026% FSO/°C
	Output < 0.0008% of Rdg./°F < 0.0014% Rdg./°C
Sealing	IP67; Dust & limited submersion

**options**

Special cable lengths, MS connectors, Custom configurations, High temperature operation and Companion instrumentation.

**dimensions**

100% CUSTOMER SATISFACTION GUARANTEED

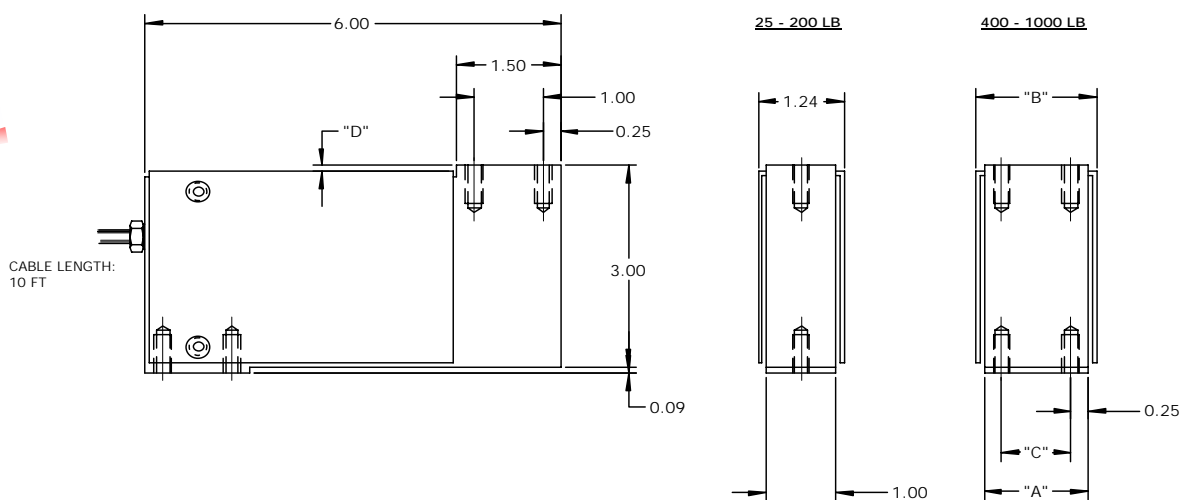

CAPACITY (LB)	"A"	"B"	"C"	"D"	THREAD	DEFLECTION (IN)	MOMENT SENSITIVITY (% RD PER IN)	MAXIMUM MOMENT (IN-LB)	PLATFORM SIZE (IN)	WEIGHT (LB)
25				0.04	1/4-28 UNF-2B x 0.5 DP	0.016	0.005	10x CAPACITY	20 x 20	4.0
50 - 100			0.04	0.013		0.005	10x CAPACITY	20 x 20	4.0	
200			0.04	0.015		0.005	10x CAPACITY	20 x 20	4.0	
400 - 500	1.00	1.25	0.50	0.04	5/16-24 UNF-2B x 0.7 DP	0.023	0.005	10x CAPACITY	20 x 20	5.0
1000	1.50	1.75	1.00	0.18		0.016	0.007	15000	30 x 30	5.5