



## Low Capacity Crane Scale

# Caston II

**The Caston II® is a compact, high performance, low capacity crane scale. The Caston II® is designed to accurately measure loads in capacities ranging from 0 to 1,000 lbs to 0 to 5,000 lbs.**



The Caston II® Series is a compact, high performance, light to medium capacity industrial crane scale housed in a painted, cast enclosure and sealed to IP65 (Multi-redundant; Low Pressure Resistant). The Caston II® Series is designed to accurately measure loads in capacities ranging from 0-1,000 lbs. full scale capacity to 0-5,000 lbs. full scale capacity. The integral loading hook and/or lifting eyes make installation and start-up quick and simple. The wireless remote system gives the operator freedom of movement during operation, and the large 1.2" high red LED display digits make reading weight data easy at a distance. The rechargeable battery is supplemented by a spare battery pack and a charging unit to make certain there is never any scale downtime for lack of power. A Low Battery annunciator is provided. Lightweight, portable, accurate and very robust, the Caston II® Series is an excellent choice for your industrial weighing and force measurement needs.

### APPLICATIONS

- Foundry Weighing
- Material Strength Pull Testing
- In-Process Weighing
- Incoming Raw Materials Weighing
- General Purpose Force Measurement

Wireless Remote Control



### Optional Handheld Indicator:

- Light weight, durable & portable
- Easy to see - simple to operate
- Wireless Connectivity
- Increased Functionality
- Built-in Rechargeable Battery
- Sun Visor



### FEATURES

- 1,000 to 5,000 lbs. Capacities
- High Safety Rating
- Hi-Visibility 1.2" Red LED Display
- Battery Operated (Rechargeable)
- Spare Battery/Charger Included
- 1:2000/1:5000 Display Resolution
- Wireless Remote Control Included
- Integral Lifting Eye/Hook Assembly
- Optional Bluetooth® Capability
- IP65 Environmental Sealing
- One Year Warranty

For more information call **1-888-545-8988**

SENTRAN, LLC 4355 LOWELL STREET, ONTARIO, CA 91761, U.S.A.

888-545-8988 T: 909-605-1544 FAX: 909-605-6305 [www.sentranllc.com](http://www.sentranllc.com)



RATED CAPACITY (lbs.)	1,000	2,000	5,000
<b>DISPLAY RESOLUTION</b>			
lbs.	1,000 X 0.5	2,000 X 1	5,000 X 2
kg.	(500 X 0.2 kg)	(1,000 X 0.5 kg)	(2,000 X 1 kg)
<b>ACCURACY</b>	±0.1% of rated capacity		
<b>MAXIMUM TARE</b>	Rated capacity		
<b>DISPLAY</b>	1.2" red LED; 5 digit; lb units		
<b>ANNUNCIATORS</b>	Low battery, zero, tare, remote control		
<b>KEYPAD</b>	On, off, zero, tare		
<b>SCALE POWER</b>	6 VDC; rechargeable battery; up to 50 hours continuous use (load cell only. 25 hours w/indicator); data retained		
<b>CHARGER</b>	120 VAC/60 HZ operation; full recharge in 3 hours		
<b>POWER USAGE</b>	1 watt		
<b>TRANSMIT RANGE (approximate)</b>	At least 50 yards (50M) in normal operating conditions		
<b>WIRELESS/RF (approximate)</b>	Line-of-sight: 300 ft outdoor, 150 ft indoor; not line-of-sight: 75 ft outdoor; frequency 433.92 mhz		
<b>RADIO</b>	Frequency modulation (FM); error detection; high telemetry reliability		
<b>LOAD CELL</b>	High strength aircraft quality alloy steel; integral hook and lifting eye(s)		
<b>TEMPERATURE RANGE</b>	14°F to 140 °F (-10 °C to 60 °C)		
<b>ENCLOSURE</b>	Robust cast aluminum housing; epoxy painted		
<b>ENVIRONMENTAL</b>	Weatherproof; NEMA 4; IP65		
<b>WARRANTY</b>	One year; limited		

## Handheld Indicator



<b>Communication Type</b>	Bluetooth
<b>Communication Rate</b>	9,600 bps
<b>Communication Distance</b>	Max: 300 ft/100m
<b>Display</b>	High Contrast 320 x 240 TFT LCD
<b>Enclosure</b>	Light weight industrial grade NEMA 4/IP65
<b>Memory</b>	100 items/5,000 transactions/time/date/gross weight
<b>Battery Charging Time</b>	Approximately 5-6 hours
<b>Options</b>	Wireless or Wired Printer
<b>Power</b>	DC 3.6V 4,400 mA rechargeable battery / DC 4.2V adapter
<b>Operating Temp</b>	14°F to 104 °F /-10 °C to 40 °C
<b>Interface</b>	USB: PC Connection / RS-232C: Mobile printer connection
<b>Dimensions</b>	4.1 (W) x 8 (H) x 2.9 (D) - Inches / 104.7 (W) x 204 (H) x 74.3 (D) - MM
<b>Product Weight</b>	1.1 lbs/0.5 kg



CAPACITY	OVERALL HEIGHT	OVERALL WIDTH	OVERALL DEPTH	LIFTING EYE I.D.	EYE TO EYE (MAX.)	WEIGHT LB(KG)
1K/2K	14.98 (380)	9.1 (230)	14.2 (360)	1.02 (26)	13.8 (350)	37.5 (17)
5K	18.65 (380)	9.1 (230)	14.2 (360)	1.02 (26)	13.8 (350)	37.5 (17)

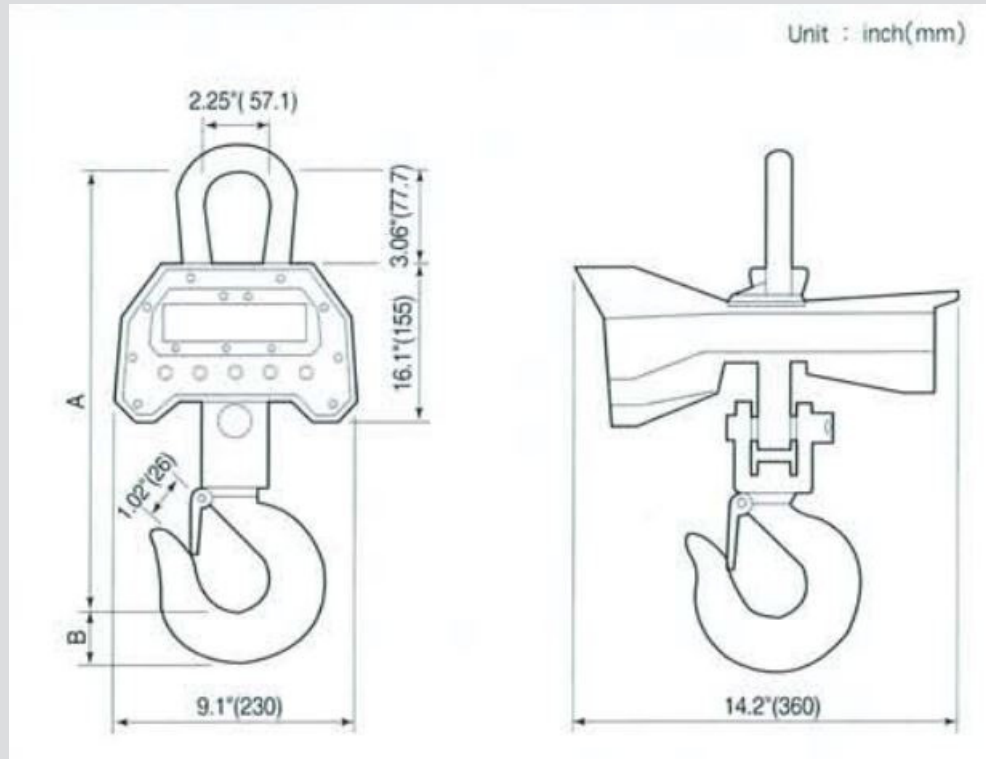

## Legal Disclaimer



ALL PRODUCTS, PRODUCT SPECIFICATIONS AND DATA ARE SUBJECT TO CHANGE WITHOUT NOTICE.

Sentran, LLC, Incorporated, its affiliates, agents, and employees, and all persons acting on its or their behalf (collectively, "Sentran, LLC"), disclaim any and all liability for any errors, inaccuracies or incompleteness contained herein or in any other disclosure relating to any product. The product specifications do not expand or otherwise modify Sentran, LLC's terms and conditions of purchase, including but not limited to, the warranty expressed therein. Sentran, LLC makes no warranty, representation or guarantee other than as set forth in the terms and conditions of purchase. To the maximum extent permitted by applicable law, Sentran, LLC, disclaims (i) any and all liability arising out of the application or use of any product, (ii) any and all liability, including without limitation special, consequential or incidental damages, and (iii) any and all implied warranties, including warranties of fitness for particular purpose, non-infringement and merchantability. Information provided in datasheets and/or specifications may vary from actual results in different applications and performance may vary over time. Statements regarding the suitability of products for certain types of applications are based on Sentran, LLC's knowledge of typical requirements that are often placed on Sentran, LLC products. It is the customer's responsibility to validate that a particular product with the properties described in the product specification is suitable for use in a particular application. No license, express, implied, or otherwise, to any intellectual property rights is granted by this document, or by any conduct of Sentran, LLC. The products shown herein are not designed for use in life-saving or life-sustaining applications unless otherwise expressly indicated. Customers using or selling Sentran, LLC products not expressly indicated for use in such applications do so entirely at their own risk and agree to fully indemnify Sentran, LLC for any damages arising or resulting from such use or sale. Please contact authorized Sentran, LLC personnel to obtain written terms and conditions regarding products designed for such applications.



### SENTRAN, LLC

4355 LOWELL STREET  
ONTARIO, CA 91761-2225, U.S.A.  
T: 909-605-1544 F: 909-605-6305

[www.sentranllc.com](http://www.sentranllc.com)

*Innovative Measurement Solutions*

